



Cut-to-size saw fh 4 / fh 5

**Compact. Precise.
Versatile.**

schelling.com

THE CUSTOMER COMES FIRST

Specific procedures and the exchange of knowledge enable your employees to add depth to their knowledge and skills who are active in the areas of preparation, programming, operation, and logistics.

All training courses are able to be adjusted to your specific needs. Normally, your employees come to our premises in this case, which possess the ideal conditions in every regard. All activities and procedures may be simulated optimally here. Presentation machines enable realistic visual lessons and hands-on work.

The Schelling training team will take care of transferring valuable insider knowledge in theory and practice to your employees on-location.

Training courses: More employee know-how increases productivity

Training courses and seminars from Schelling contribute to the optimal use and care of the machines purchased by you right from the start and secure and increase productivity, precision, reliability, and life cycle.

Anyone who chooses the best can expect strong service.

Industrial companies and demanding craftsmen who choose cut-to-size and precision saws from us consciously select the world's leading and pioneering technology. We provide a level of quality that can hardly be beaten, which is based on our own research and development, solid construction, and high-quality components. We measure the lifetime of our machines in decades.

With our decentralised organisation, which features multiple locations and a global network, your Schelling service employees are quickly at your side, around the world.

Prevention check*:

A free test for even more availability

Anyone who has invested in a Schelling machine wants to ensure their value and productivity and remain prepared for possible adjustments to the current state of the technology. The prevention check is an instrument developed by Schelling. This is available free of charge and for the lifetime of the machine.

* Available in Austria, Germany, Italy, Switzerland, Belgium, Netherlands, Luxembourg.

On-site in a flash and parts deliverable in 24 hours

When worse comes to the worst, speedy help is the best help. That's why the Schelling repair service organisation is decentralised. It's also why in 2014, Schelling invested in a new, highly modern, central replacement parts warehouse, which is able to deliver to any location on the planet within 24 hours.

Our highlights for you:

- Hotline support throughout the entire lifetime of your Schelling saw – FREE*
 - 25 years guaranteed replacement parts
 - You always have the same customer support person at Schelling. He knows your machine best of all.
 - We are available to you 365 days a year, 24 hours a day – in your neighbourhood
- * Applies during regular working hours, work days 7:00 am – 5:00 pm



THE HIGHEST LEVEL OF
AUTOMATION IN ITS CLASS.

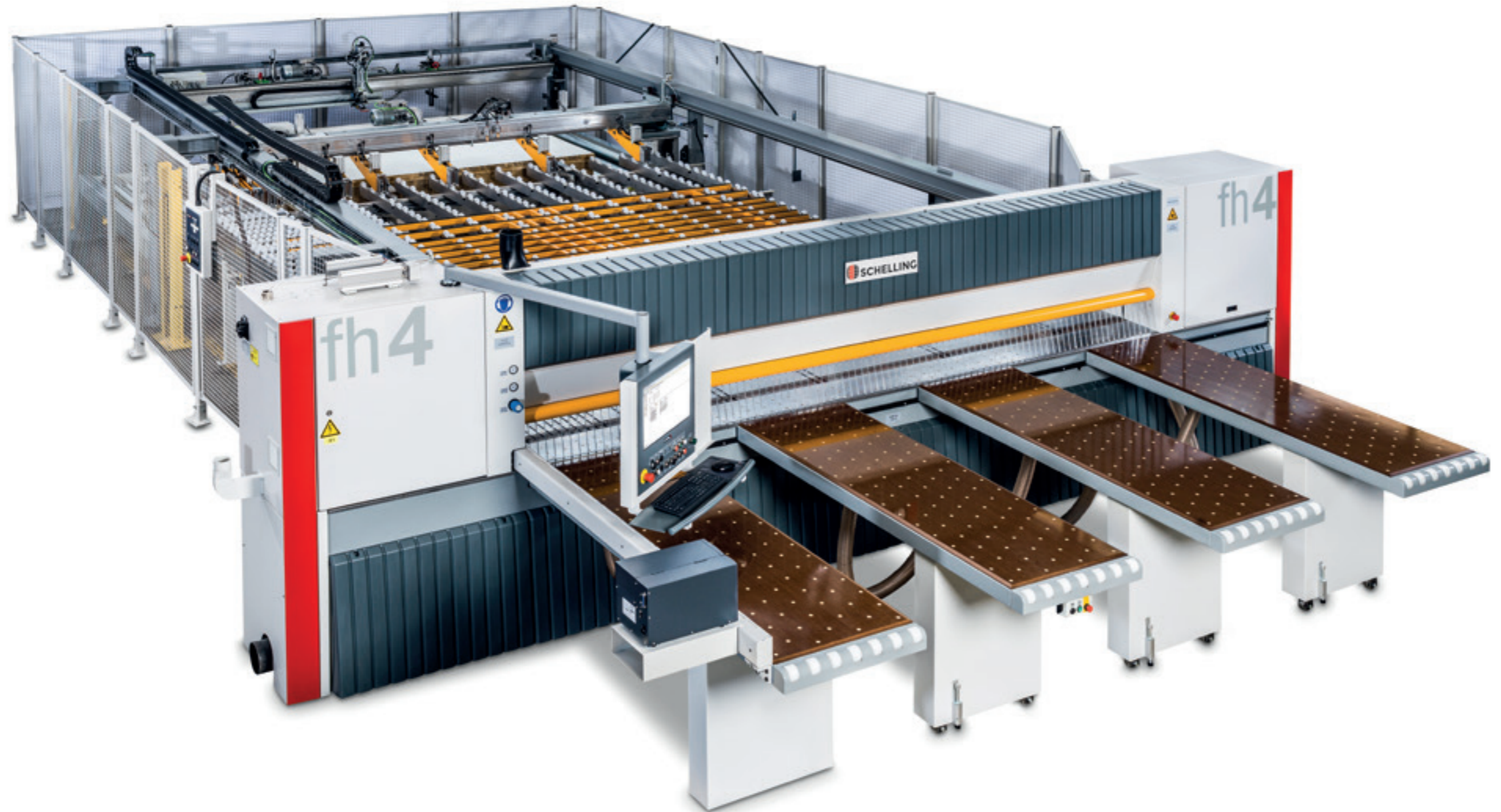

The fh 4 / fh 5 cut-to-size saw offers maximum productivity and precision. One of its main strengths is its speed and flexibility to process cuts of both individual panels as well as multiple panels.

With the fh 4 / fh 5, AUTOMATION needs to be written in capital letters. It sets new standards for efficient cut-to-size panels for the trade or industrial application with the highest possible automation in its class. The variety of automatic settings and automatically monitored functions ensures optimized and harmonious operational sequences.

INTELLIGENT FEATURES INCREASE PRODUCTIVITY.

The fh 4 / fh 5 is characterised by many automatically-monitored functions. This ensures optimized and harmonious operational sequences. The actual format, as well as the book height of the material being processed is detected automatically via integrated sensors.

Saw travel and saw stroke are executed simultaneously, which results in shorter cycle time. The saw travel speed adjusts automatically to the book height being processed, assuring maximum feed speeds. Also, the pressure of the pressure beam is self regulating based on the size and height of the book being processed assuring optimal hold down pressure.

Saw unit: Ideal implementation of force

The Schelling fh 4 / fh 5 cut-to-size saw has the unique "Evolution" drive concept and offers an optimally matched ratio of motor power and useable book height. The saw motor is fixed in place on the saw carriage, thus it does not move with the saw blade. This permits strong motors with higher power while saving energy costs.

The optimized chip routing system which is integrated in the saw carriage allows for the immediate disposal of chips from the cutting area. This in turn results in longer saw blade service life.

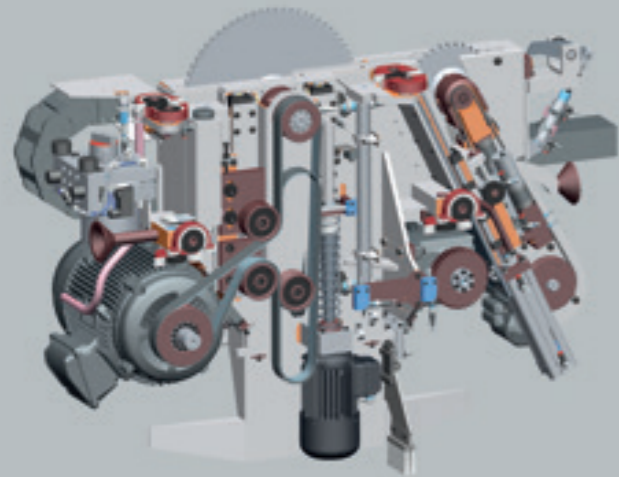

The DUPLUS2 concept uses two feeders that position the material at the saw line independently from each other. This results in significant performance increases. With this concept the machine can either divide a head part and main part simultaneously or process two strips simultaneously in a staggered cutting pattern.



Automatic label printing is a unique feature from Schelling. In this process labels are printed and applied at the infeed area of the machine before the cutting process. Labels are applied to the entire panel in the respective spot of the finished part before cutting. The final position within the part can be freely selected. For turned parts, the label applicator can rotate the label 90 degrees. With this system, labels are applied while the previous panel is being processed, eliminating the need for manual label application after cutting, therefore dramatically increasing productivity.



The retractable bottom clamping parts enable a material push out to the end of the machine table with the clamps. An ergonomic advantage that benefits the operator by making the takeover of boards or books easier, thus increasing efficiency.



HIGHEST PRECISION OVER THE ENTIRE SERVICE LIFE.

Push-off carriage

The separate push-off carriage permits simultaneous loading of the saw and division of the panels. This helps increase productivity.

Turning device

The Schelling turning device makes automatic execution of head cuts and longitudinal cuts possible without interruption or manual interference. Each of these turns is executed in 90 degree steps. In this process the speed is automatically adapted to the actual material book height. This results in short and precise processing cycles. The Schelling turning device has been developed for automatic loading cut-to-size machines and angular systems.



The Schelling high-performance flat guide is used for saw aggregates, feeder and separate push off carriages. It stands for the highest level of precision for the entire service life of the machine. It also ensures that maintenance costs stay low.

The dual strip aligners, one before and one after the saw line remain on the material during the cut ensuring maximum angular precision. The alignment force adjusts automatically to the material thickness or package height with the aid of a frequency converter. This means that even thin panel strips can be cut with high precision.

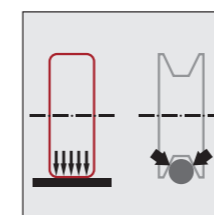

System comparison:
Line contact - no point load

PRECISION WHEREVER YOU LOOK.

Format device: For panels with overhanging surfaces.

The Schelling format device allows for cutting of material with surface overhang all around the panel. The trimming fixtures required for this are mounted directly on the clamps. The feeder clamps offset automatically to the entered overhang dimension to the format stops allowing for precise alignment of the material and secure clamping even several panels high.

The Schelling format device also includes software for format post processing. The software offers the following functions:

- Adjustable search criteria (job name, format number, position number, line number, etc.)
- Graphic presentation of the format with the appropriate edge and corner definition
- Cutting pieces in pre-cut size, oversize or finished size

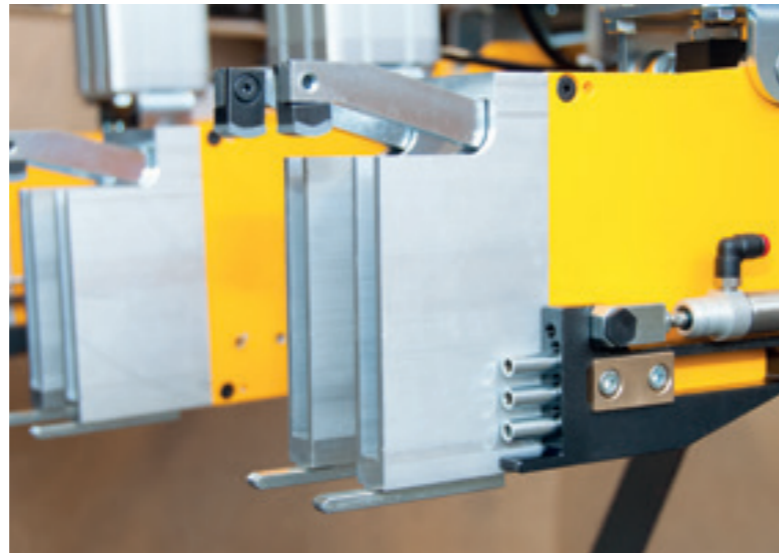

Air cushion tables: Convenient operation.

The widened and moveable air flotation tables offer optimal work surface and can be positioned where the operator needs them.

Cut Quality: Edge/Jump scoring for soft or post-formed edges.

With the ascending scoring saw blade the entry and exit edges are scored for soft-formed and post-formed panels. Thus tear-free cuts are achieved.





MATERIAL TRANSPORT: ADAPTED TO EVERY REQUIREMENT.



Material loading and handling are essential performance characteristics for increasing the efficiency of a cut-to-size saw. Schelling offers specifically built loading, material handling and stacking solutions that can be tailored to individual requirements. A single source for everything from planning to commissioning.

Vacuum in-feed: Transport of panels with sensitive surface



Manual stacking: Easy material handling



Area storage system: Increased productivity

HANDLING: SAFE AND GENTLE ON MATERIAL.

With automatic in-feed the lift table adjusts itself precisely to the set number of panels to be divided. (For panel thicknesses from 10 mm). The push-off rods move the book of material from lift table onto the roller table.

Special push-off spindles are used to handle panels from a thickness of 6 mm as well as wavy material.

Also thin panels with a thickness under 6 mm can be pushed off of the stack with single-piece precision, using Schelling's thin board push-off and retaining device.



PRODUCTION SEQUENCE DIAGRAM

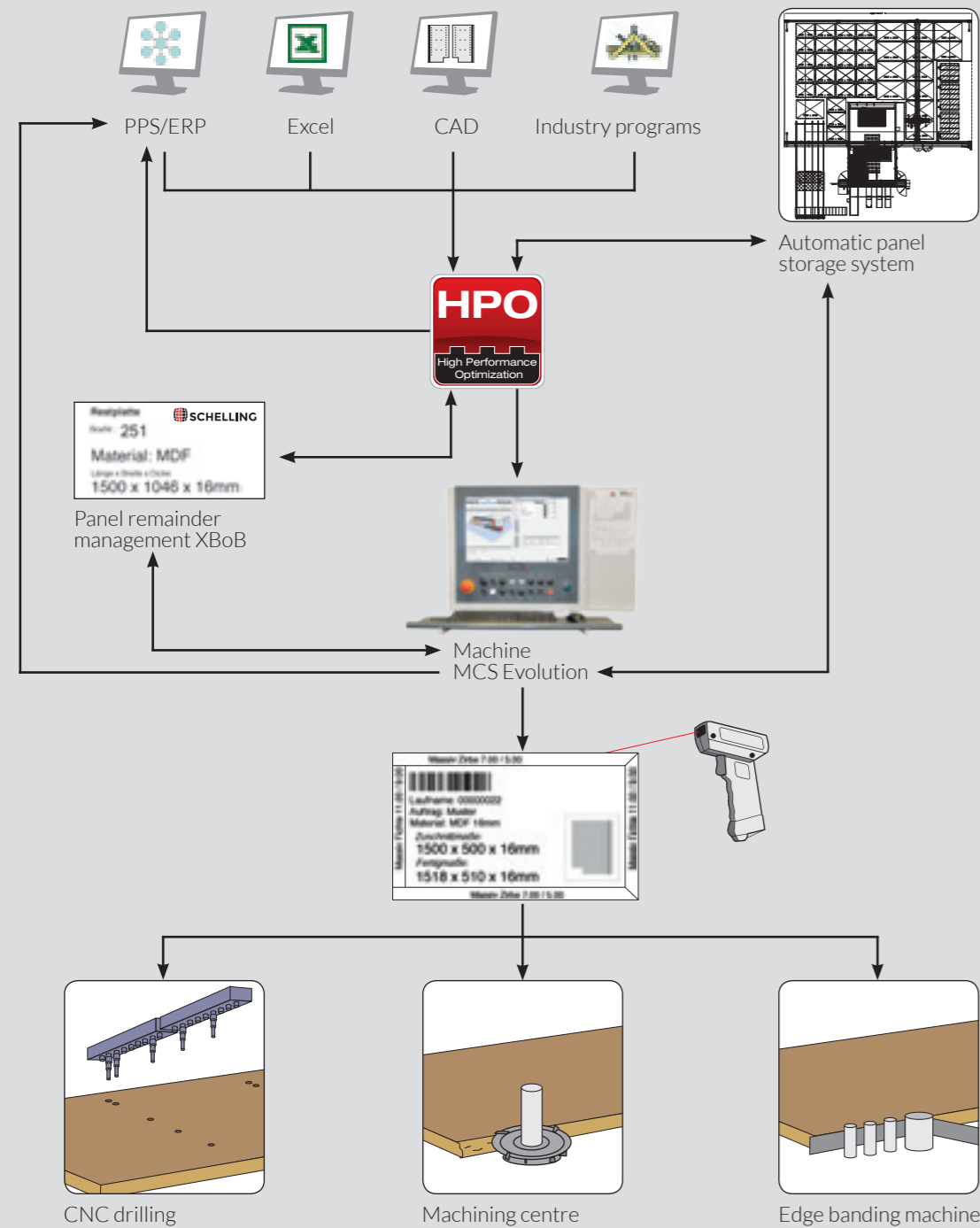

CONTROL DESK: EASE OF OPERATION.

Schelling's easy-to-operate "MCS Evolution" control software and "HPO" optimization software make operating the saw a breeze. Sequences are represented in real-time mode with unsurpassed fault diagnostic. Self explanatory operator guidance particularly eliminate operating errors, therefore increasing availability and machine efficiency.

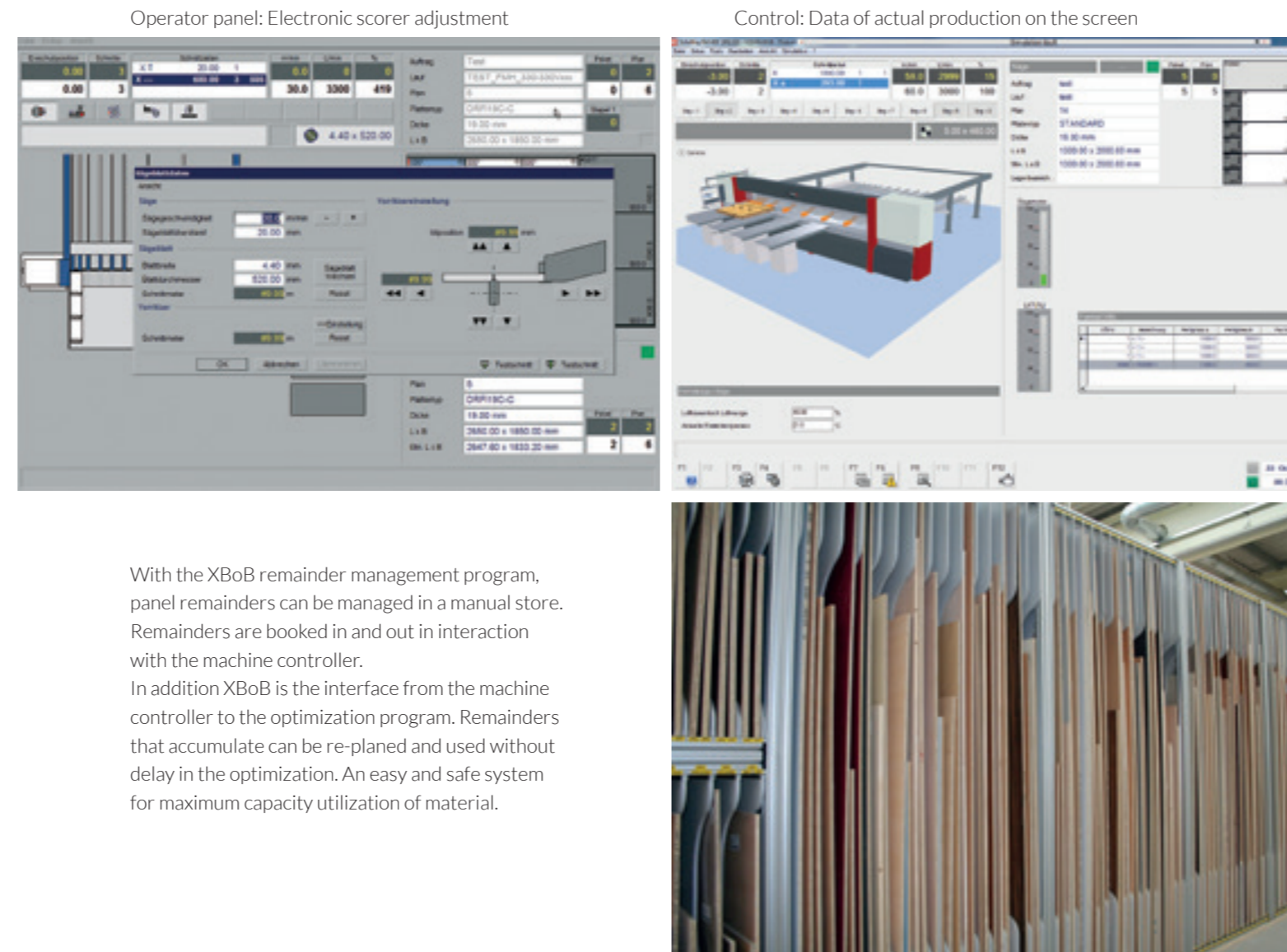

With the XBoB remainder management program, panel remainders can be managed in a manual store. Remainers are booked in and out in interaction with the machine controller. In addition XBoB is the interface from the machine controller to the optimization program. Remainers that accumulate can be re-planned and used without delay in the optimization. An easy and safe system for maximum capacity utilization of material.

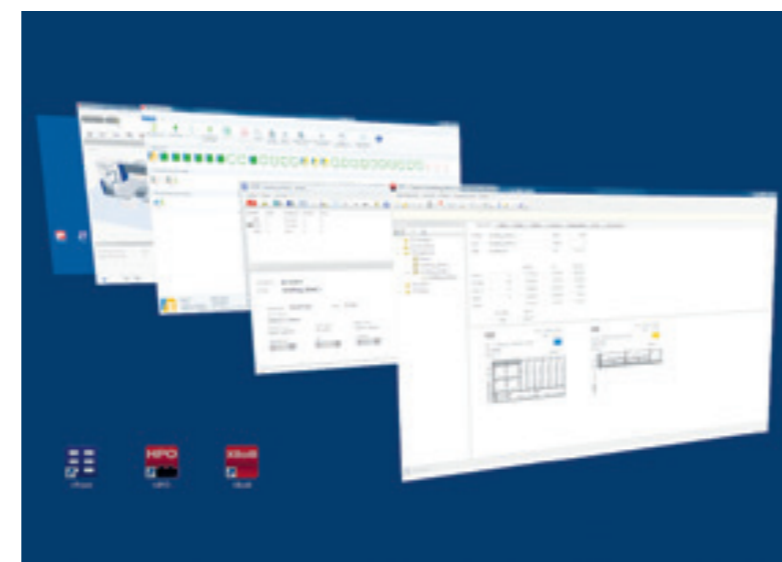

The current release of the HPO cutting plan optimization presents new functions for productivity and operating convenience. Multi-core use ensures the speed available from state-of-the-art hardware is effectively utilised. Thus computing times are reduced by as much as 60%. In addition the system works with the latest computer core. Another new feature is that the appearance of plans can be virtually set as desired, on request the optimal un-machined panel can be determined, the print function can be configured and searching has been even more clearly designed.

TECHNICAL DATA

Saw blade

Diameter fh 4	360 mm / 14.173"
Projection fh 4	105 mm / 4.134"
Clamp opening fh 4	105 mm / 4.134"

Diameter fh 5	400 mm / 15.748"
Projection fh 5	125 mm / 4.921"
Clamp opening fh 5	125 mm / 4.921"

Power

Saw motor fh 4 / fh 5	18 / 21 kW
Saw motor fh 4 / fh 5	24.5 / 28.5 HP

Dimension fh 4 / fh 5 manual

	330	430	580
a	3330 / 131.00"	4330 / 170.50"	5830 / 229.50"
b	5750 / 226.00"	6750 / 265.75"	8250 / 324.80"
c	3650 / 143.70"	4650 / 183.00"	6150 / 253.90"
d	6800 / 267.75"	7800 / 307.00"	9300 / 366.25"
e	4680 / 255.00"	5680 / 223.60"	7180 / 282.70"

Weight

330	6.500 kg / 14,250 lbs
430	7.500 kg / 16,500 lbs
580	9.500 kg / 21,000 lbs

Dimension fh 4 / fh 5 automatic

	330x160	330x220	430x160	430x220	580x220
a	3330 / 131.00"	3330 / 131.00"	4330 / 170.50"	4330 / 170.50"	5830 / 229.50"
b	5750 / 226.00"	5750 / 226.00"	6750 / 265.75"	6750 / 265.75"	8250 / 324.80"
c	3650 / 143.70"	3650 / 143.70"	4650 / 183.00"	4650 / 183.00"	6150 / 253.90"
d	7700 / 303.15"	8750 / 344.50"	8750 / 344.50"	9750 / 383.90"	11000 / 433.00"
e	5100 / 200.80"	6200 / 244.00"	6100 / 240.20"	7200 / 283.50"	8200 / 322.80"

Dimensions - mm / inch

Weight

330	9.000 kg / 19,750 lbs
430	11.000 kg / 24,250 lbs
580	12.500 kg / 27,500 lbs

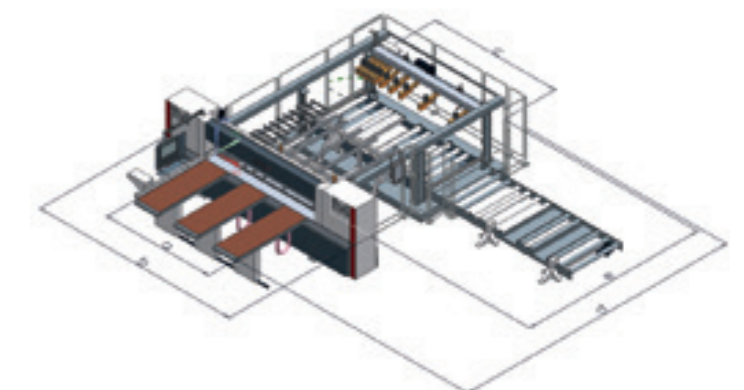
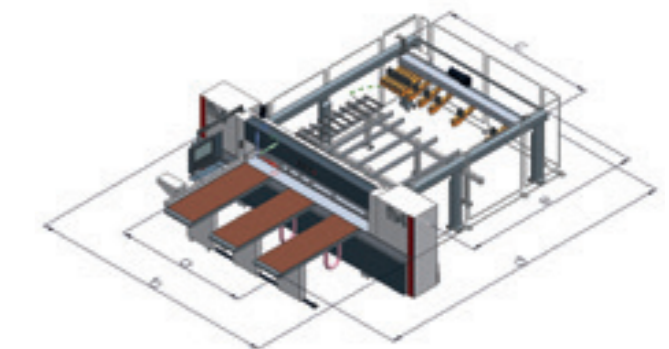



**ONE GROUP –
ONE GOAL:
EXPERTISE IN
DEVELOPING
SOLUTIONS
FOR THE
WOODWORKING
INDUSTRY**

The IMA Schelling Group is a reliable partner for implementing of sophisticated system solutions. The demands of our customers are a daily challenge to us, our know-how and creativity! We work with you to develop innovative and unique solutions for wood processing.

www.imaschelling.com

Subject to technical modifications and amendments and to further developments. The offer, respectively the order confirmation is relevant in either case!
The picture of the machine could have been taken without complete protection devices. The protection device is part of the scope of delivery.
Photos could also be options, not being part of the scope of delivery.